

— PRODUCT DATA SHEET · LI SERIES

LI-81XB Lithium-Ion Battery Pack

High-capacity drop-in replacement for the Yaesu FT-817, FT-817ND and FT-818ND portable transceivers. 3S 18650 architecture with integrated BMS, external charging port, and full-rated TX power on every band.

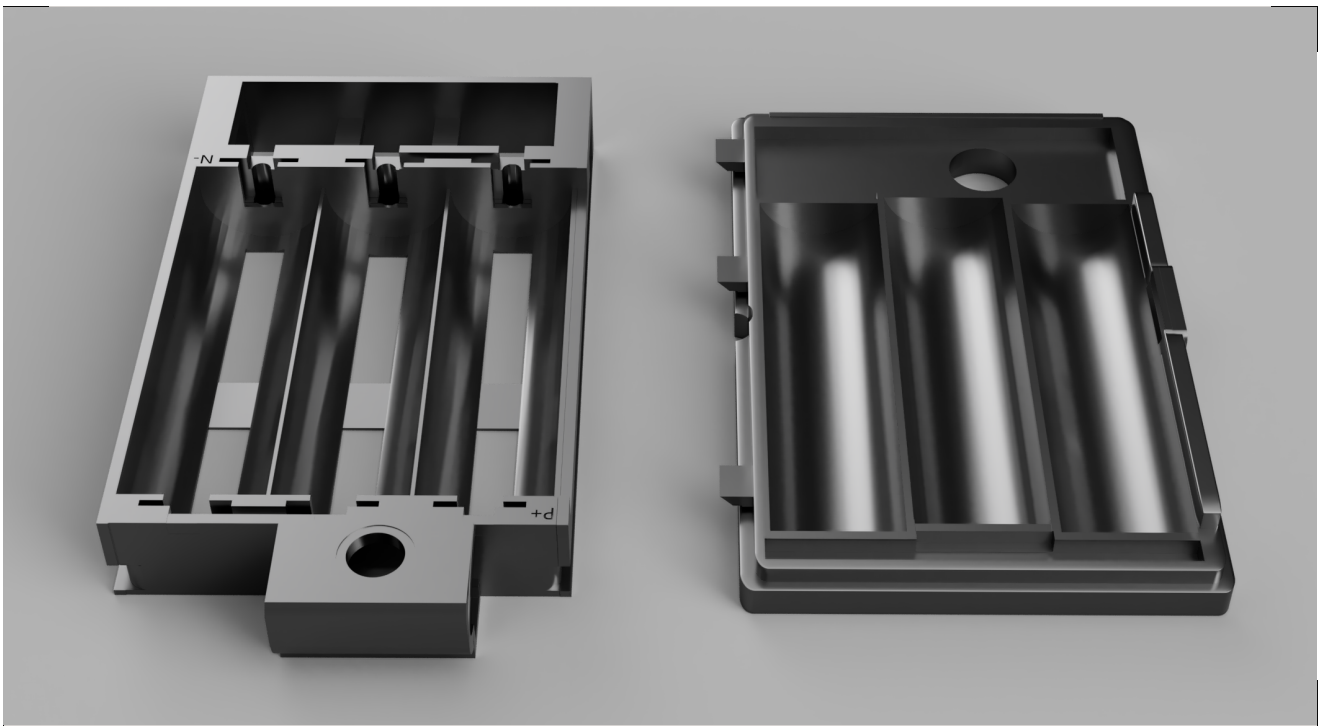

DOCUMENT NO.	REVISION	ISSUE DATE	CLASSIFICATION
DS-LI81XB-0100	A / 01	2026-05-17	Public

01 Product Overview

The Lambda Industries LI-81XB is a high-capacity, drop-in lithium-ion battery replacement engineered specifically for the Yaesu FT-817, FT-817ND and FT-818ND portable transceivers.

Using three protected 18650 cells rated at 3200 mAh each in a 3S series configuration, the LI-81XB delivers more than double the energy capacity of the factory Ni-MH pack while occupying the same internal battery bay.

An integrated Battery Management System (BMS) provides over-charge, over-discharge, over-current and short-circuit protection on a per-cell basis, with a 10 A continuous discharge ceiling that gives more than 5x headroom over the transceiver's peak current draw. A dedicated external charging port allows fast, safe charging from the supplied 12.6 V charger — bypassing the transceiver's slow internal trickle charger.

COMPATIBILITY

The LI-81XB is a direct, no-modification replacement for the Yaesu FNB-72 and FNB-85 battery packs supplied as standard with the FT-817, FT-817ND and FT-818ND.

The FT-817 family of transceivers is among the smallest HF/VHF/UHF multimode general-coverage amateur radio transceivers available, well suited to portable use thanks to its internal battery pack — and the LI-81XB is designed to make full use of that portability advantage.

<p>CAPACITY</p> <p>3200 mAh</p> <p>≈ 35.5 Wh</p>	<p>VOLTAGE</p> <p>11.1 V</p> <p>12.6 V full → 9.0 V cut-off</p>	<p>DISCHARGE</p> <p>10 A</p> <p>BMS continuous ceiling</p>
<p>CHARGE TIME</p> <p>2–3 hrs</p> <p>via supplied 12.6 V charger</p>	<p>CYCLE LIFE</p> <p>≥ 500</p> <p>charge / discharge cycles</p>	<p>CELLS</p> <p>3 × 18650</p> <p>button-top, not included</p>



NOTE

18650 cells are not supplied.

Three matched button-top cells with a positive terminal stud are required for operation — see §05 Recommended cells.

02 Technical Specifications

Comparison against the OEM Yaesu FNB-85 pack supplied as standard with the FT-818ND.

PARAMETER	LI-81XB	STOCK FNB-85
CHEMISTRY & CELLS		
Chemistry	Lithium-Ion (18650, 3S1P)	Nickel-Metal Hydride
Cell rating	3.7 V nom, 3200 mAh × 3	—
Cell type required	18650 button-top (positive stud); protected or unprotected	—
ELECTRICAL		
Nominal pack voltage	11.1 V	9.6 V
Voltage range (full → cut-off)	12.6 V → 9.0 V	≈ 10.0 V → 8.4 V
Rated pack capacity	3200 mAh (≈ 35.5 Wh)	1400–1500 mAh (≈ 14.4 Wh)
Continuous discharge (BMS limit)	10 A	—
Typical TX current @ 5 W out	≈ 1.9 A	≈ 1.9 A
Discharge headroom	> 5× radio peak draw	minimal
PROTECTION & CHARGING		
BMS protection	Per-cell 0V / UV / OC / SC	None
Charging	External 5.5 × 2.1 mm DC jack, 12.6 V	Through-radio only
Charge time (typical)	2–3 h from supplied charger	≈ 10 h via radio @ 200 mA
Cycle life	≥ 500 cycles	300–500 cycles
Internal charging via radio	Must not be used (see §05)	Enabled
MECHANICAL		
Form factor	Drop-in, FNB-72/85 footprint	OEM

03 Performance Advantages

Why upgrade from the stock Ni-MH pack.

01 More than 2x the energy capacity

The stock FNB-85 is a 9.6 V / 1400 mAh Ni-MH pack delivering roughly 13–14 Wh of usable energy. The LI-81XB delivers approximately 35.5 Wh — a 2.5x improvement. In real-world field use, where the FT-818ND's internal battery is typically good for only about 1.5 hours before the outing has to end, the LI-81XB extends a single charge to a full day's portable operation for most users.

02 Full-rated TX power on every band

The FT-817/818 family draws roughly the same current at a given power output regardless of supply voltage — at 5 W, the FT-817 draws ≈ 1.9 A whether the supply is 9.6 V or 13.8 V — but the RF output the radio can actually deliver is voltage-dependent. At 8–10 V the '817 cannot produce a full 5 W on all bands; by 11 V the full output power is essentially available.

The radio also defaults to 2.5 W on the internal battery because the stock Ni-MH pack sits at ≈ 9.6 V nominal. With the LI-81XB supplying 11.1 V nominal (up to 12.6 V freshly charged), the transceiver operates within its preferred input window and delivers full rated output — 5 W on the FT-817/817ND and 6 W on the FT-818ND — across all bands, from the internal pack.

03 Massive discharge headroom

At 5 W TX the radio draws ≈ 1.9 A, well under 1C for the 3200 mAh cells (3.2 A = 1C). The LI-81XB's BMS is rated for 10 A continuous discharge — over five times the radio's peak demand. This headroom keeps the cells cool and well within their safe envelope, directly translating to longer cycle life and stable voltage under load (no sag-induced power dropout during long CW or digital-mode transmissions).

04 Dramatically faster, safer charging

The FT-817's onboard charger is designed for Ni-MH chemistry and is current-limited. When supplied with 13.8 V on the rear-panel connector, the radio charges the internal pack at only 160–200 mA — meaning a fully discharged 1.4 Ah pack requires two consecutive 6-hour charge cycles. The radio also applies a continuous ≈ 25 mA trickle to protect Ni-MH cells from self-discharge — a behaviour that is incompatible with lithium chemistry and can cause an unprotected Li-Ion pack to catch fire.

The LI-81XB solves both problems. Its dedicated external 5.5×2.1 mm charging jack routes the supplied 12.6 V charger directly to the BMS, completely bypassing the radio's internal charger. A standard 12.6 V charger replenishes the pack in 2–3 hours, with the BMS providing per-cell over-voltage cut-off during the CV phase to prevent any individual cell from being overcharged.

3.5 Multi-layer protection circuitry

Every LI-81XB ships with a fully integrated 3S Battery Management System providing:

- Per-cell over-voltage protection (cut-off at 4.25 V/cell, ±0.05 V)
- Per-cell under-voltage protection (cut-off at 2.8 V/cell)
- Over-current protection (10 A discharge ceiling)
- Short-circuit protection (auto-recovery on fault clear)
- Reverse-polarity protection on the charge input

This eliminates the well-known risks of using bare 18650 cells without overcharge protection, where the user must otherwise carefully monitor input voltage during every charge cycle.

3.6 No memory effect, low self-discharge, longer shelf life

Ni-MH cells lose a measurable percentage of their charge per week sitting in the radio. The 18650 Li-Ion cells used in the LI-81XB retain typically > 90% of their charge after six months of storage, so the radio is ready to operate when you are — important for emergency-communications and SOTA/POTA use cases where the radio may sit idle between activations.

3.7 Same footprint, same weight class

The LI-81XB is mechanically a drop-in replacement. Installation requires no modification to the transceiver, no removal of the internal Ni-MH charger circuit, and no soldering. The pack weighs approximately the same as the stock FNB-85 (within 10 g), preserving the radio's balance for handheld use.

04 What's in the Box

LI-81XB battery tray with integrated BMS	1 ×
LI-81XB battery compartment cover with external charging port	1 ×
12.6 V / 1.5 A wall charger, 5.5 × 2.1 mm DC plug	1 ×
Installation and safety guide	1 ×
Compliance & warranty card	1 ×



NOTE

18650 cells are not supplied. Three matched button-top 18650 cells are required for operation. See §05 — *Recommended cells*.

05 Installation

Read this entire section before you begin. The installation procedure is straightforward, but the FT-817's internal battery connector is fragile and a small amount of care during fitting will save a great deal of frustration later.

BEFORE YOU BEGIN – IMPORTANT WARNINGS



The transceiver's internal battery connector is delicate. Handle it gently at all times. The connector pins and the wiring loom inside the transceiver can be damaged easily if levered or pulled. Always disconnect the internal battery connector before removing the old battery, and only reconnect it once the new battery tray has been fully installed.



Do not use metal tools to fit or remove cells, the battery tray or the battery cover. A slipped screwdriver can short a cell, gouge the BMS, or damage the transceiver chassis. If leverage is needed, use a plastic spudger, a nylon guitar pick, or a similar non-conductive tool.



Only use 18650 cells with positive terminal studs (commonly called “button-top” cells). Flat-top and tab/solder-welded cells will not make reliable contact with the LI-81XB tray and are mechanically incompatible with this housing.

RECOMMENDED CELLS AND WORKSPACE

For best performance, install three matched 18650 cells: same manufacturer, same model, same capacity rating, and ideally from the same production batch. Cells should also be at the same state of charge when installed (typically all freshly charged, or all at storage voltage of ≈ 3.7 V). Mismatched cells will work but will reduce overall pack capacity, balancing performance and cycle life.



Two known-good button-top cells for the LI-81XB, both available in the UK:

- **RadioMaster 3200 mAh 18650** – hobbyrc.co.uk/radiomaster-3200mah-18650-cells-2pcs (HobbyRC)
- **Panasonic NCR18650B 3350 mAh** (button-top) – nubattery.co.uk/panasonic-ncr18650b-18650-battery (NuBattery)

Work on a clean, flat, well-lit surface protected with a soft cloth or anti-static mat. Remove any antennas, microphones, headphones and DC power leads from the transceiver before beginning.

5.1 Removing the standard battery

- 01** **Power off the transceiver.**
Disconnect any external DC supply, antenna, microphone and accessories.

- 02** **Position the radio for access.**
Place the transceiver upside down on the protected work surface, with the front face of the radio pointing away from you. The battery compartment is now uppermost.

- 03** **Open the battery compartment.**
Pull the compartment latch — located in the middle at the top of the cover — towards the top of the radio. The standard cover may need to be levered very gently near the latch to free it from the housing. **Use a plastic tool only.**

- 04** **Disconnect the internal battery connector.**
With the cover removed, locate the internal battery connector. Carefully disconnect the FNB-85 (or FNB-72) by gripping the connector body — **not the wires** — and easing it straight off its mating header. Do not rock or twist the connector.

- 05** **Lift the old battery out.**
Remove the original pack from the compartment.

- 06** **Retain the original parts.**
Place the original battery and battery cover somewhere safe — ideally back in the radio's original shipping carton if you still have it. Retaining the original parts means the radio can always be returned to factory configuration in future.

5.2 Installing the LI-81XB battery tray

The LI-81XB tray is intentionally a tight fit in the battery compartment. It should slide in firmly but should never require force; if it appears to jam, withdraw it, check the orientation and try again.

01 Do not install the cells yet.

The tray must be **empty** when it is fitted into the radio.

02 Orient the tray.

Position the LI-81XB tray so the battery connector is on the right-hand side of the radio — the same side as the transceiver's internal battery connector.

03 Slide the tray into the compartment.

Tilt the tray slightly and slide it into the battery compartment, moving towards the left. You may need to pull back the battery compartment latch to allow the tray to clear it.

04 Seat the BMS enclosure.

Continue sliding the tray left. The BMS enclosure is shaped to fit under the recess on the left-hand side of the transceiver — verify that it seats into this recess as the tray reaches its final position.

05 Check cable clearance and press home.

Before pushing the tray fully home, check that the tray's battery connector cable is not trapped underneath the tray or against the chassis. When clear, press the tray gently into the compartment until it is fully seated.

... continued on page 09.

5.2 Installing the LI-81XB battery tray (continued)

06**Reconnect the radio's internal battery connector.**

Connect the transceiver's connector to the LI-81XB tray. Make sure both connectors are correctly oriented before pressing them together; the connector is keyed but can be stressed if forced the wrong way around. A useful technique: gently rest the tray-side connector face-up on the tray, then press the transceiver's connector down onto it. **Do not pull on the wires** — always grip the connector body.

07**Tuck the cable away.**

Once the connectors are firmly mated, tuck the cable down into the compartment so it cannot be trapped between the battery cover and the transceiver housing when closed.

08**Install the three 18650 cells.**

Correct polarity is essential. The tray does not carry printed polarity markings; instead, each cell position has a coil spring at one end and a flat or slightly recessed contact at the other. The spring is the **negative** terminal — fit each cell with its flat end (negative) against the spring, and its button-top stud (positive) against the flat contact. A cell inserted backwards will compress the spring at the wrong end and may appear to fit, but will trip BMS protection on first use and can damage the cells.

09**Engage the new battery cover.**

Take the LI-81XB cover and orient it so the three engagement prongs are along the bottom edge. Tilt the cover upwards, engage the prongs into the bottom face of the battery compartment, and slowly close the cover towards the radio. You may need to pull back the compartment latch to let the cover travel fully home.

10**Close and verify the latch.**

The new cover is a deliberately tight fit. Gentle, even pressure across the cover should be enough to seat it flush with the transceiver housing — the latch will click when fully engaged. If the cover does not close easily, **do not force it**; open it back up and check that the tray is fully seated, the internal connector is tucked away, and the cells are correctly oriented.

06 Charging & Operation



WARNING

Do not use the radio's internal charger. The Yaesu FT-817/817ND/818ND does not provide a user-accessible menu option to disable the internal Ni-MH charging circuit. The LI-81XB must be charged **only via its dedicated external charging port**. Never connect a 13.8 V supply to the radio's rear-panel DC input with intent to charge through the transceiver — doing so may permanently damage the pack, the BMS, and/or the radio, and in extreme cases may cause the cells to vent, overheat or ignite. When the LI-81XB is installed, treat the radio's rear-panel DC input strictly as an operating power input, never as a charging input.

6.1 Charging procedure

Connect the supplied 12.6 V charger (1.5 A) to the external charging jack on the battery cover. A typical full charge from the BMS low-voltage cut-off takes \approx **2 h 15 min**. The BMS regulates and terminates the charge cycle internally.

The LI-81XB may also be charged from any regulated 12.6 V DC source capable of supplying at least 1 A, including suitable solar charge controllers. **Do not use supplies exceeding 12.7 V**, as this exceeds the BMS's safe input window and may cause the protection circuit to disconnect or, in repeated cases, fail.

6.2 Operating notes

- The radio's on-screen battery icon is calibrated for Ni-MH and will read “full” across most of the Li-Ion discharge curve, then drop relatively quickly near the BMS cut-off. This is normal; the BMS will cleanly disconnect the load at 9.0 V (\approx 3.0 V/cell).
- Output power on the FT-817ND/818ND will remain at the user-selected level (up to 5 W / 6 W respectively) across the full useful discharge range, rather than dropping to 2.5 W as it does with the stock Ni-MH battery.
- If the pack becomes noticeably warm during transmit, the discharge rate is approaching the cell C-rating limit; reduce TX duty cycle or output power until the pack returns to ambient temperature. In normal operation at 5–6 W the LI-81XB runs cool.
- Rated for operation from -10 °C to $+50$ °C. Charging below 0 °C is inhibited by the BMS.

07 Safety, Warranty & Document Control

SAFETY INFORMATION

- Do not charge the LI-81XB through the radio's rear-panel DC input or by any other means that activates the transceiver's internal Ni-MH charging circuit. Use the dedicated external charging port exclusively.
- Do not short-circuit the charging jack or the radio battery contacts.
- Do not disassemble the pack; there are no user-serviceable parts inside, and disassembly will damage the BMS.
- Dispose of 18650 cells at an approved Li-Ion recycling facility at end of life.
- Dispose of the battery tray (containing the BMS) in the small electrical (WEEE) section of a recycling facility at end of life.

WARRANTY

The LI-81XB is covered by a 12-month limited warranty against defects in materials and workmanship under normal use. Cycle-life degradation, physical damage, and damage caused by use of non-approved chargers are excluded.

Warranty claims should be raised through support@lambdaind.uk with proof of purchase and a description of the fault.

DOCUMENT CONTROL

REV	DATE	AUTHOR	SUMMARY OF CHANGES
A / 01	2026-05-17	Mark Wickens	Initial release.